



eDART Installation and Maintenance Manual - Actuator

Babcock Business Park · Cnr Jet Park and North Reef Roads · Jet Park · Gauteng · South Africa
Landline: +27.11.823.6620 · info@edart.co.za · sales@edart.co.za · www.edart.co.za



Document eDART Installation and Maintenance Manual - Actuator

Issue Number 2.1

Date of Issue September 2011

Manufacturer eDART Slurry Valves (Pty) Ltd
Reg No: 2000/023276/07
cnr Jet Park and North Reef Roads
Jet Park
Gauteng
Tel. +27.11.823.6620
www.edart.co.za
info@edart.co.za

Contact eDART
Tel. +27.11.823.6620
email: **maintenance@edart.co.za**



WARNING

eDART Slurry Valves (PTY) LTD will in no way be liable for any loss or injury or death caused to any person or persons or property following this installation and maintenance manual.



eDART Installation and Maintenance Manual - Actuator

Babcock Business Park · Cnr Jet Park and North Reef Roads · Jet Park · Gauteng · South Africa
Landline: +27.11.823.6620 · info@edart.co.za · sales@edart.co.za · www.edart.co.za

TABLE OF CONTENTS

1. Introduction.....	3
2. Significant Equipment Details	3
3. Routine Maintenance And Inspection	3
4. Disassembly Of The Actuator	4
5. Disassembly Of The Fail Action Actuator (Spring)	8
6. Inspection.....	9
7. Reassembly Of The Actuator	10
8. Reassembly Of Bias Spring Actuator	12
9. Reassembly of Pedestal.....	Error! Bookmark not defined.
10. eDART Safety	13
11. Problems.....	13



NOTE

Please read through this entire document before any procedures are executed.



WARNING

eDART Slurry Valves (PTY) LTD will in no way be liable for any loss, death or injury caused to any person or persons following this installation and maintenance manual.

© Copyright 2011 eDART Slurry Valves (PTY) LTD

This document is subject to copyright. The content of this document may not be copied or reproduced in part or full without the prior written consent of the owner.



eDART Installation and Maintenance Manual - Actuator

Babcock Business Park · Cnr Jet Park and North Reef Roads · Jet Park · Gauteng · South Africa
Landline: +27.11.823.6620 · info@edart.co.za · sales@edart.co.za · www.edart.co.za

1. INTRODUCTION

This document is the maintenance manual for the eDART actuator range. It provides the guidelines for the disassembly, maintenance and re-assembly of the pedestal and actuator.

2. SIGNIFICANT EQUIPMENT DETAILS

The EDA actuators have their external components made from Stainless Steel and the internal components are made from Aluminium. The pneumatic barrel is made from Glass Reinforced Plastic.

3. ROUTINE MAINTENANCE AND INSPECTION

It is important to operate the actuator on a regular basis.

If the normal duties do not require the actuator to operate regularly we recommend that a procedure be introduced to stroke the actuator on a weekly basis.



NOTE

Should the actuator not operate on a regular basis, please introduce a procedure to stroke the actuator on a weekly basis.

The advantage of this is that cylinder lubrication is achieved and any possible problems that may occur are identified before consequential damage can result.

4. DISASSEMBLY OF THE ACTUATOR

Please read through this whole procedure before starting the disassembly.

1. Remove all air connections to actuator.
2. Disconnect air connections and linkages of the positioner if appropriate and remove positioner.
3. Remove stem clamp or unscrew actuator from connecting stem as appropriate.
4. Unscrew the 4 nuts holding the actuator to the valve pedestal.
5. Remove air fitting from bottom port.

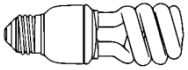

Tip

It is easier to use an allen key inserted into the pneumatic fitting rather than to use a spanner on the nut on the outside.

6. If spring pack is used, remove M8 nuts holding the self-contained spring unit onto the top plate and lift the spring pack off. See §5 for complete information for the addition steps when maintaining an actuator with a spring pack.



WARNING

Ensure the spring is in the lowest energy state before loosening any nuts, i.e. make sure that nothing is preventing the actuator from properly stroking under spring action



WARNING

Do not attempt to open the spring unit as this could result in serious injury or death. The spring is live.

7. Remove the front plate by unscrewing the two capscrews holding it in position (Figure 1).
8. Loosen the capscrews of the band clamps holding the two halves of the cover tube. Lift off the top band.
9. Open the two halves of the cover tube and lift off top plate.
10. Slide cylinder tube up off the bottom plate and piston (see Figure 2).
11. Push out the piston sub-assembly from the bottom plate.
12. Remove lock nut from actuator stem and separate piston plates (see Figure 3).

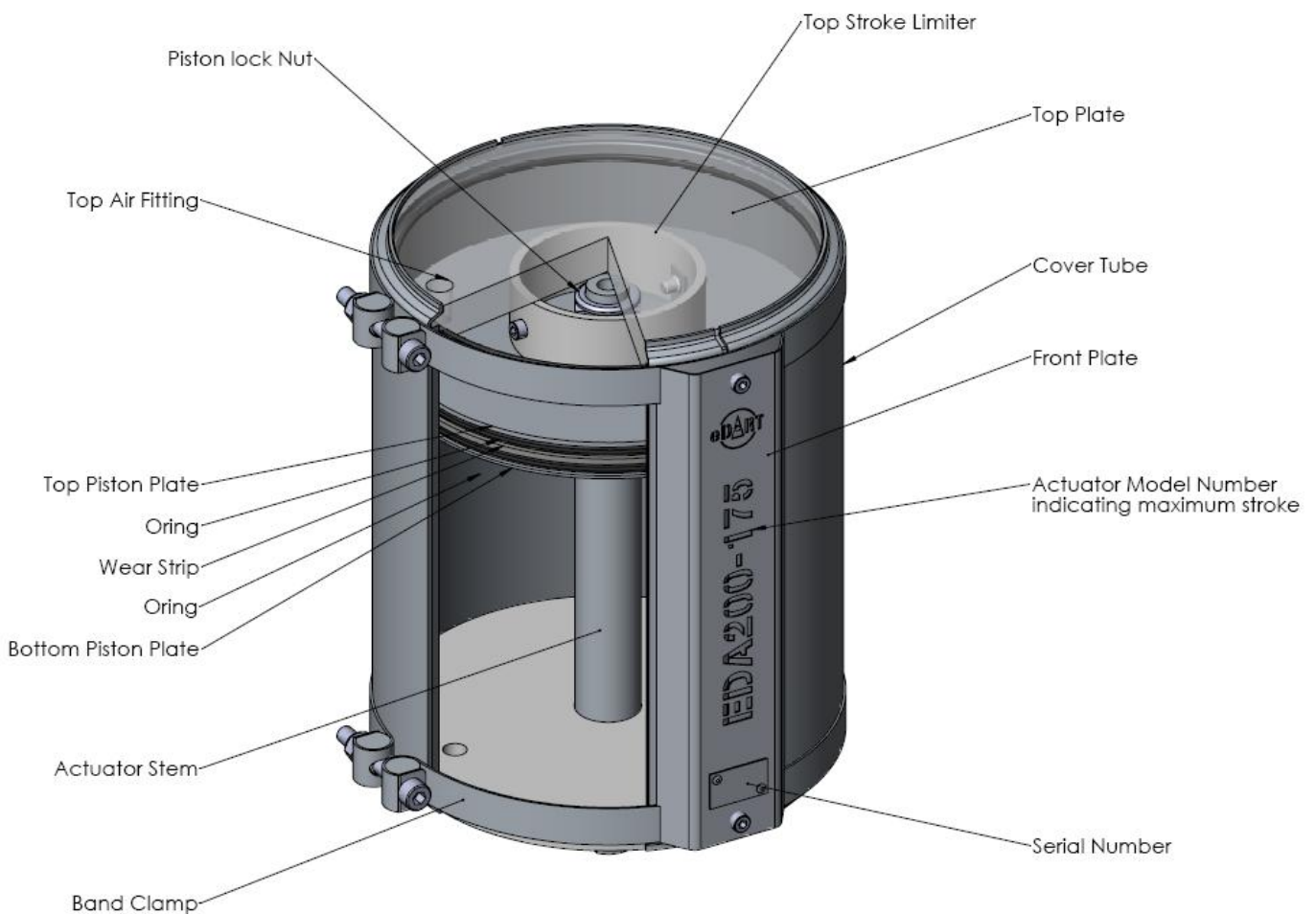

Figure 1: A view of the assembly with sections of the top plate, cover tube and cylinder tube removed so as to show the piston sub-assembly.

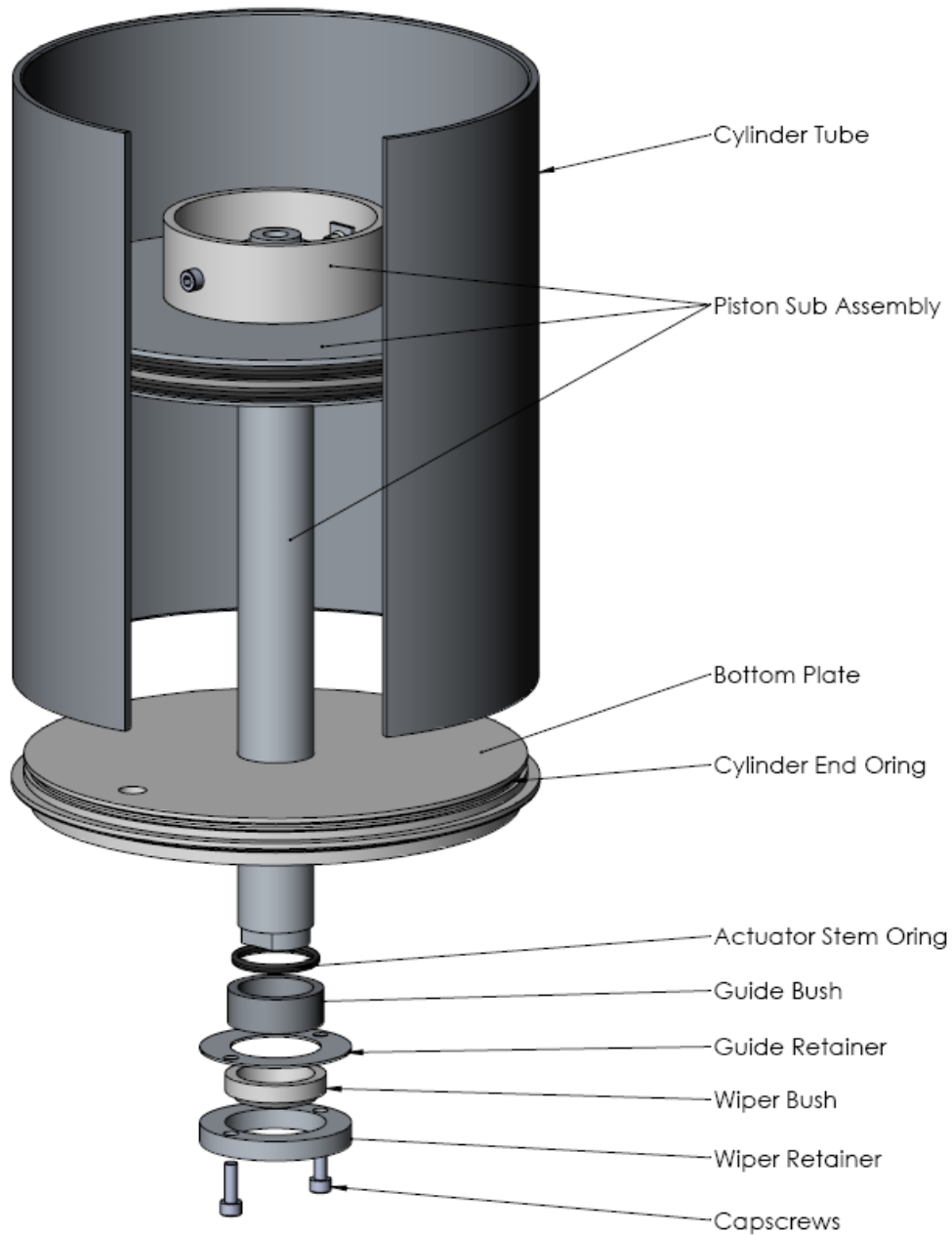

Figure 2: Once the top plate and cover tube have been removed, slide the cylinder tube off the bottom plate and over the piston. Also note the order of the guides and Orings in the bottom assembly.

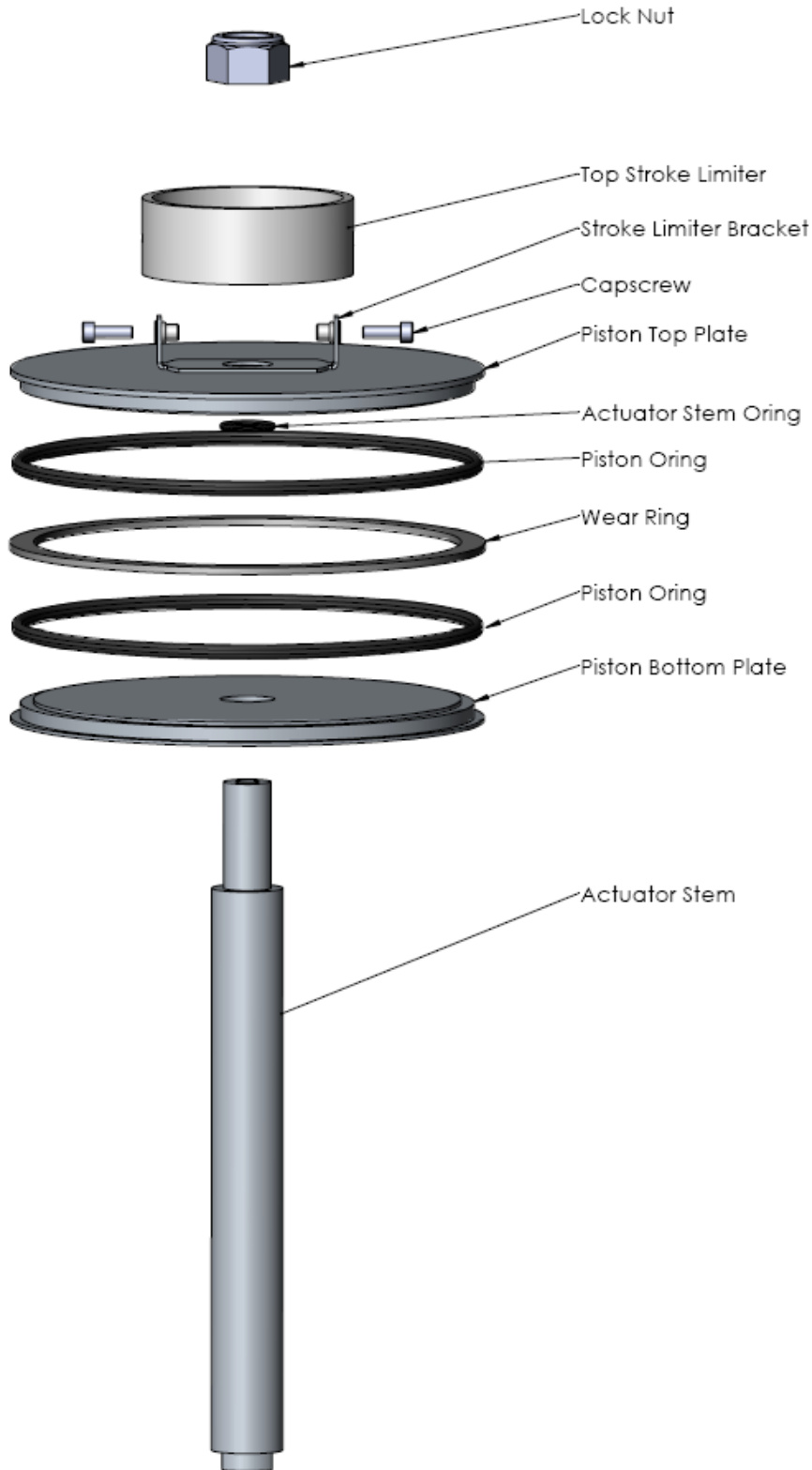

Figure 3: An exploded view of the piston sub-assembly. To disassemble the piston, unscrew the Nylok and separate the top and bottom piston plates. Exercise caution when properly locating the Actuator Stem Oring upon re-assembly.

5. DISASSEMBLY OF THE FAIL ACTION ACTUATOR (SPRING)

Follow the steps given in § 4 to disassemble the actuator body. Read through this whole procedure before starting the disassembly.



WARNING

The spring unit is self-contained.

Do not attempt to open the spring unit, failure to ignore this warning may result in serious injury or death

Bias Retracted

Bias Extended

HD Retracted

HD Extended

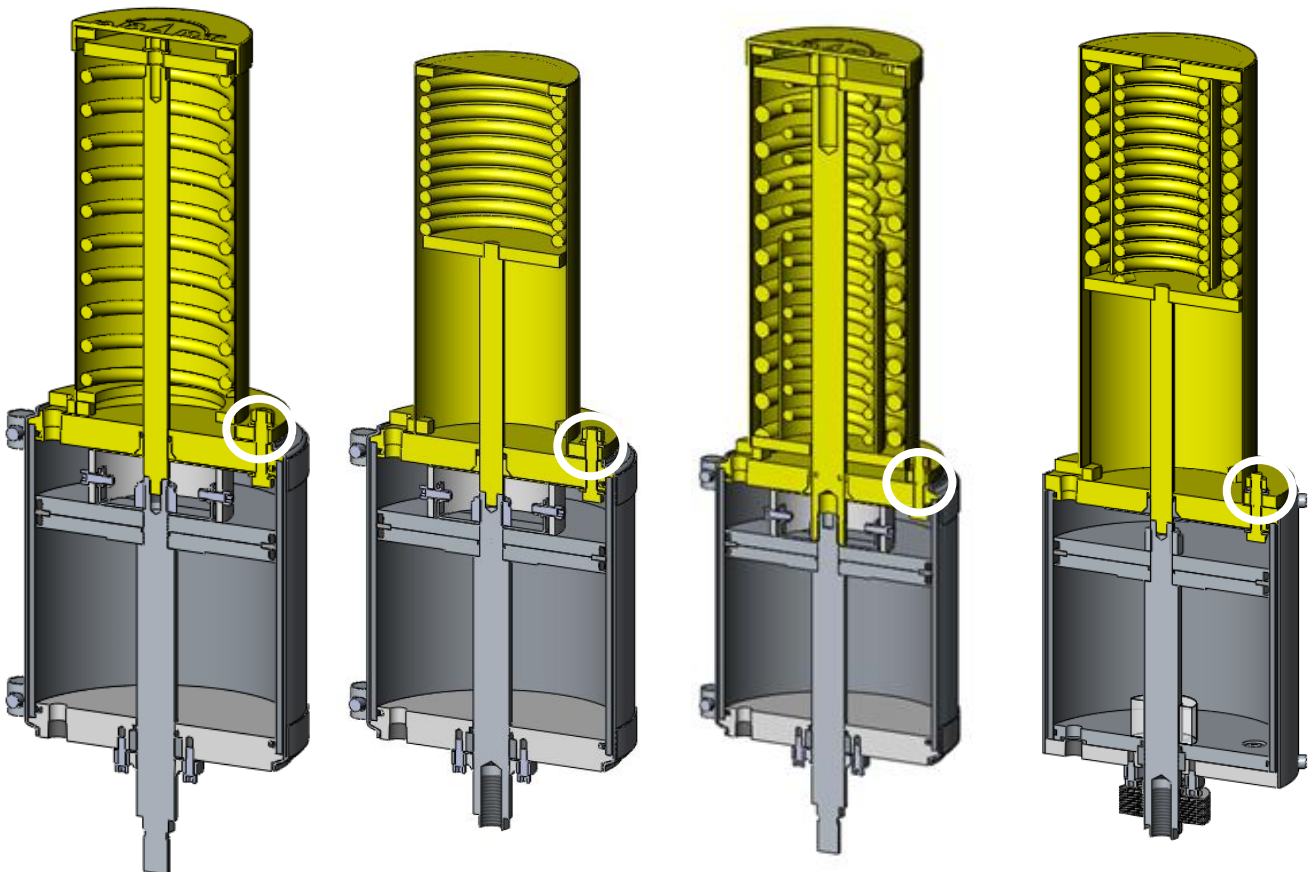

1. The spring unit can be removed from the top plate by removing the M8 Nuts.



WARNING

Ensure the spring is in the lowest energy state before loosening any nuts, i.e. make sure that nothing is preventing the actuator from properly stroking under spring action



eDART Installation and Maintenance Manual - Actuator

Babcock Business Park · Cnr Jet Park and North Reef Roads · Jet Park · Gauteng · South Africa
Landline: +27.11.823.6620 · info@edart.co.za · sales@edart.co.za · www.edart.co.za

2. Remove the push rod from within the cylinder. For the Fail Retracted versions the nut inside the top of the spring pack securing the tension rod to the “Movable” spring button must be unscrewed.

3. The top plate contains a push rod Oring and a guide bush. These can be removed by loosening the M8 set screws and removing the Guide Retainer Plate. A pneumatic torque wrench would be required to do so as loctite is used to create the air seal on the set screw threads. Please replace these bolts and use a adhesive (i.e. loctite) to provide the seal again.

6. INSPECTION

All parts must be inspected for wear and corrosion.

Thoroughly investigate all worn parts to determine the cause of the damage.

The particular areas of these components that need to be inspected include the following:

Component	Criteria				
	Erosion	Corrosion	Galling	Wear	Scoring
Orings				✓	
Bushes				✓	
Cylinder bore	✓	✓	✓		✓
Actuator Stem			✓	✓	✓

Any significant area of damage should be reported to eDART Slurry Valves directly – Clean all metal components with a suitable solvent (isopropanol or rubbing alcohol).



7. REASSEMBLY OF THE ACTUATOR

The following parts must be replaced:

- Piston Orings (use pneumatic grease to lubricate).
- Cylinder end Orings.
- Actuator stem Orings.
- Guide bushes if damaged.

To replace these parts:

1. Replace the small Oring and Bottom Guide Bush into the recess of the bottom plate.
2. Place the thin Guide Retainer plate into place.
3. Gently press the Wiper Bush into the Wiper Retainer and bolt to the bottom plate so as to retain the Guide Retainer with its Guide Bush and Actuator Stem Oring
4. Hold the actuator stem on the flats at the bottom end in a soft jaw vice.
5. Fit the bottom piston plate (the one with the Oring recess) onto the actuator stem.
6. Insert piston stem Oring. Ensure the Oring is properly located (see Figure 3).
7. Place the PTFE Wear Ring onto the bottom piston plate.
8. Replace top piston plate and the thin stroke limiter bracket. Tighten with the Nylok nut. (Not applicable for the Heavy duty fail retracted version)
9. Insert the piston assembly into the bottom assembly. Ensure the bottom Oring does not get damaged.
10. Put light smear of silicon grease on the piston Orings and fit to the piston.
11. Replace the cylinder end Oring into groove on the bottom plate and apply a light coating of silicon grease.
12. Apply liberal coating of grease to the bore of the cylinder. Please do not score the bore.

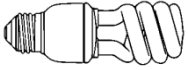

Tip

Use the back side of an old hacksaw blade to help smear the grease everywhere. Perhaps grind off the teeth to prevent accidental scoring of Actuator parts.

13. Slide the cylinder tube over the piston and piston Oring. Do not damage the Oring.
14. Once the piston is located in the cylinder tube, straighten the tube and slide it onto the lower end plate and over the Oring. Do not damage the Oring.
15. Replace the top stroke limiter pipe.
16. Fit the top plate Oring into the groove of the top plate and apply a light smear of grease. Fit plate onto the cylinder tube, ensure that the top and bottom air fittings are aligned as shown in Figure 1. Slide the recessed part of the top plate into the cylinder tube until the lip of the top plate rests on the cylinder tube. Make sure not to damage the Oring.
17. Line up the halves of the cover tube, band clamps, front plate, rotate the top and bottom plates so the air fittings are aligned as shown in Figure 1. Tighten Band Clamp
18. Check cylinder operation using an air line. Pressure should be approximately 5 Bar.
19. Stroke the actuator to ensure smooth operation of the actuator. Should the piston not operate smoothly please repeat procedure from step 13 or call eDART for further assistance.



WARNING

DO NOT EXCEED 10 (Ten) BAR when pressurizing the cylinder.

8. REASSEMBLY OF BIAS SPRING ACTUATOR

Follow the steps to reassemble an actuator given in §7 until point 16.

1. When reassembling the top plate, insert the Oring and top guide into the recess. Hold in place using the retaining plate and the M8 set screws. Use loctite on the setscrews to create the pneumatic seal. Tighten evenly.
2. Ensure that there is a Top Stroke Limiter on piston nut. All bias spring units have this - it will be a minimum of 35mm long.
3. Depending on the model, insert the bias spring push rod for the fail extended version or for the retracted versions screw the tension rod on top of the actuator stem.
4. Fit the top plate Oring and apply a light smear of grease. Fit plate onto the cylinder tube ensuring the push, or tension, rod is still located. Please ensure that the air fittings, top and bottom, line up.
5. Line up the halves of the cover tube, band clamps, front plate, ensure that the top and bottom plates so the air fittings are aligned as suggested in Figure 1.
Tighten Band Clamps
6. Replace the spring pack.
 - a. For the Retracted version, ensure the push rod is located in the hole on the spring pack bottom, then fasten the nut on the stud in the top of the tension rod so that the "movable" spring button is held in place.
 - b. For the extended version the piston will need to be pushed down into the extended position
7. Replace and tighten the M8 nuts. This will add pre-compression to the spring pack.
8. For the retracted versions, put the Spring Pack PU cap back into place.

9. eDART SAFETY

1. The eDART Actuator from 250 and down can be handled by hand, those above 300 are to be lifted using the lifting eye.



WARNING

Under no circumstances may an entire valve be lifted by the lug on the actuator! That will break the actuator.

2. Due consideration is to be given to the weight of the components before dismantling.
3. Rigging equipment and procedures are to be followed to service the eDart.
4. Safety procedures for the use of compressed air are to be followed.
5. Only suitably qualified persons to work on or maintain eDART Actuators.
6. All local safety rules and regulations with respect to safety clothes applicable, tools and equipment used and methods of operation are to be adhered to.

10. PROBLEMS

For any problems please contact eDART Slurry Valves directly on –

**Tel. +27. (0) 11. 823. 6620, or
email: maintenance@edart.co.za**

Document	eDART Installation and Maintenance Manual - Actuator
Manufacturer	eDART Slurry Valves (Pty) Ltd • Reg No: 2000/023276/07 • cnr Jet Park and North Reef Roads • Jet Park • Gauteng • Tel. +27.11.823.6620 • www.eDART.co.za • info@edart.co.za
Contact	eDART • Tel. +27.11.823.6620 • email: maintenance@edart.co.za • web: www.edart.co.za



WARNING

eDART Slurry Valves (PTY) LTD will in no way be liable for any loss or injury or death caused to any person or persons or property following this installation and maintenance manual.